

GENERAL DESCRIPTION

The DS9034PCX PowerCap[®] is designed to be a lithium power source for nonvolatile timekeeping RAMs in Dallas Semiconductor's directly surface-mountable PowerCap Module (PCM) package. After a PowerCap module board has been soldered in place and cleaned, the DS9034PCX PowerCap is placed on top of the PCM board to form a complete PowerCap module package. The PowerCap is keyed to prevent incorrect attachment.

The DS9034PCX can be easily removed by inserting a regular screwdriver into a detachment feature and prying gently outward and upward to release the PowerCap from the PowerCap module board.

ABSOLUTE MAXIMUM RATINGS

Storage Temperature Range: -40°C to +85°C

Stresses beyond those listed under "Absolute Maximum Ratings" may cause permanent damage to the device. These are stress ratings only, and functional operation of the device at these or any other conditions beyond those indicated in the operational sections of the specifications is not implied. Exposure to the absolute maximum rating conditions for extended periods may affect device.

BATTERY CHARACTERISTICS

Nominal Voltage: 3V

Nominal Capacity: 130mAh

Chemistry: Li(CF)_x

CRYSTAL CHARACTERISTICS

Nominal Frequency: 32.768kHz

Load Capacitance: 6pF

FEATURES

- Provides 10 Years of Battery Backup Power for Nonvolatile Timekeeping RAMs in the PowerCap Module Package (PCM)
- Snaps Directly Onto Surface-Mounted PowerCap Module Boards
- Detachment Feature Allows Easy Removal
- Compatible with these 34-Pin PowerCap Module Boards:

DS1386P	DS1543P/YP/WP
DS1486P	DS1553P/YP/WP
DS1643P	DS1554P/YP/WP
DS1644P	DS1556P/YP/WP
DS1646P	DS1557P/YP/WP
DS1647P	DS1744P/YP/WP
DS1743P/WP	DS1746P/YP/WP
DS1251YP/WP	DS1747P/YP/WP
DS1248YP/WP	
DS1244YP/WP	

PACKAGE INFORMATION

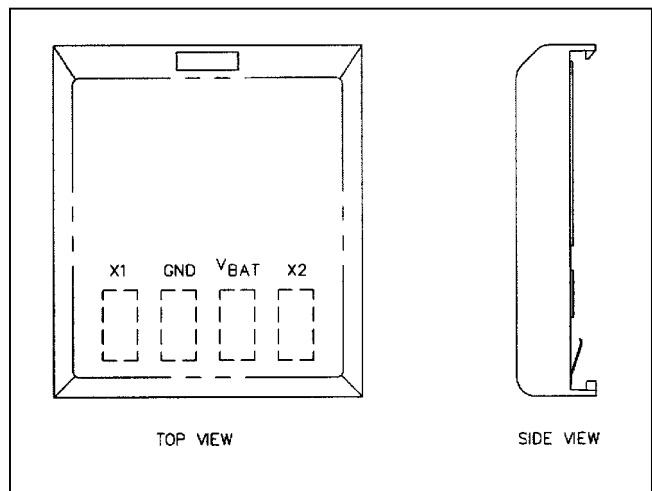

PIN DESCRIPTION

NAME	FUNCTION
X1, X2	32.768kHz Crystal Connections
V _{BAT}	+3V Battery Output
GND	Ground

PowerCap is a registered trademark of Dallas Semiconductor.

ORDERING INFORMATION

PART	TEMP RANGE	VOLTAGE (V)	PIN-PACKAGE	TOP MARK*
DS9034PCX	0°C to +70°C	3.0	PCM	DS9034PCX
DS9034PCX+	0°C to +70°C	3.0	PCM	DS9034PCX
DS9034I-PCX	-40°C to +85°C	3.0	PCM	DS9034PCXI
DS9034I-PCX+	-40°C to +85°C	3.0	PCM	DS9034PCXI

+ Denotes a lead-free/RoHS-compliant device.

* A "+" on the top of the package indicates a lead-free device.

PowerCap ATTACHMENT AND REMOVAL

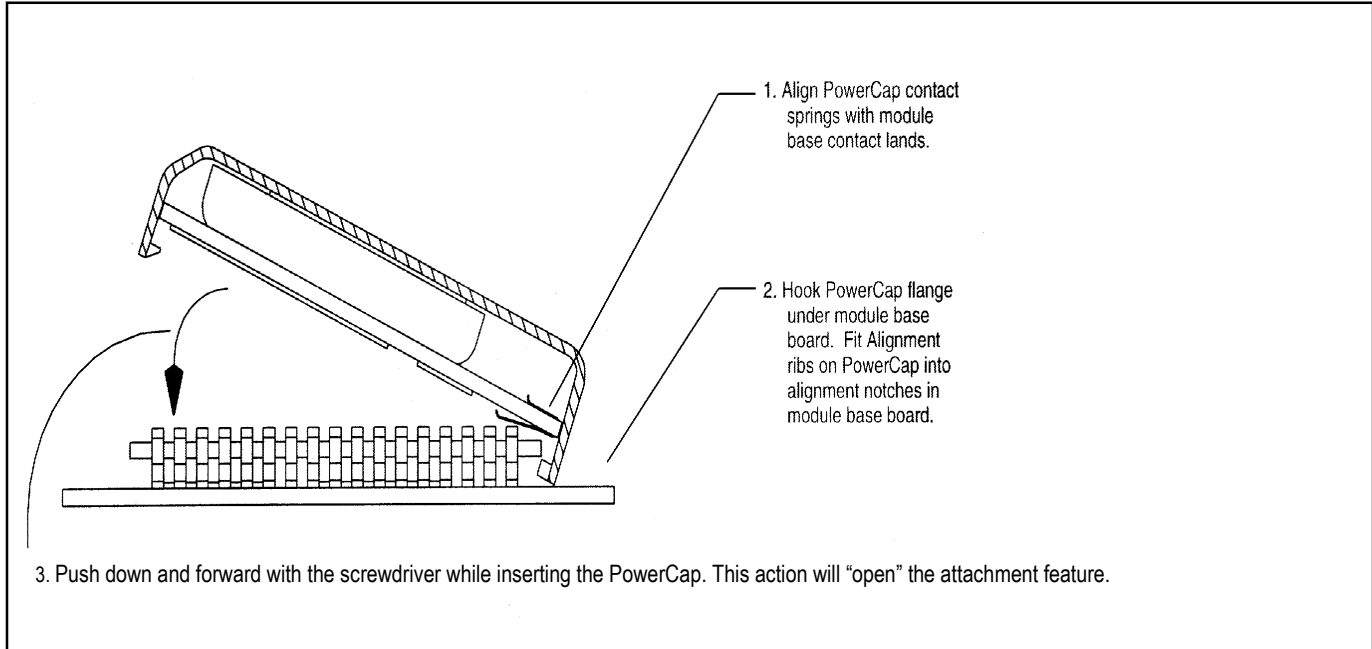

PowerCap REMOVAL

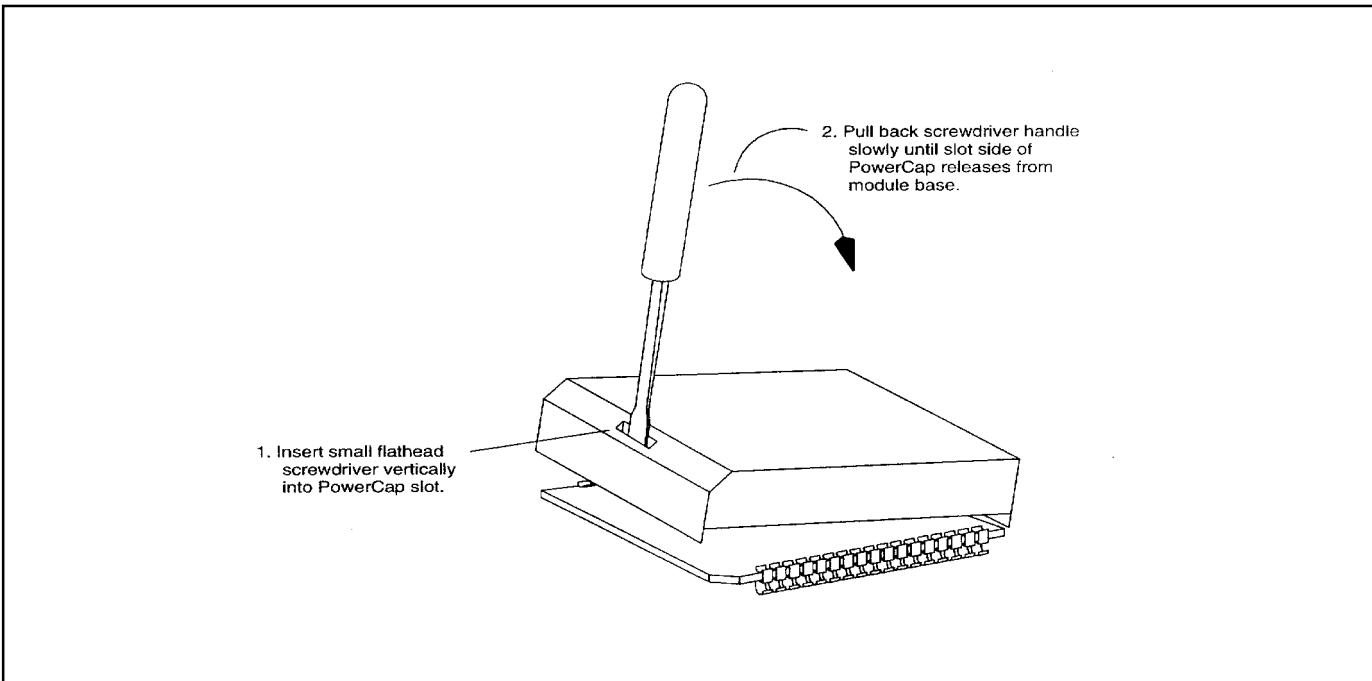

PACKAGE INFORMATION

(The package drawing(s) in this data sheet may not reflect the most current specifications. For the latest package outline information, go to www.maxim-ic.com/DallasPackInfo.)

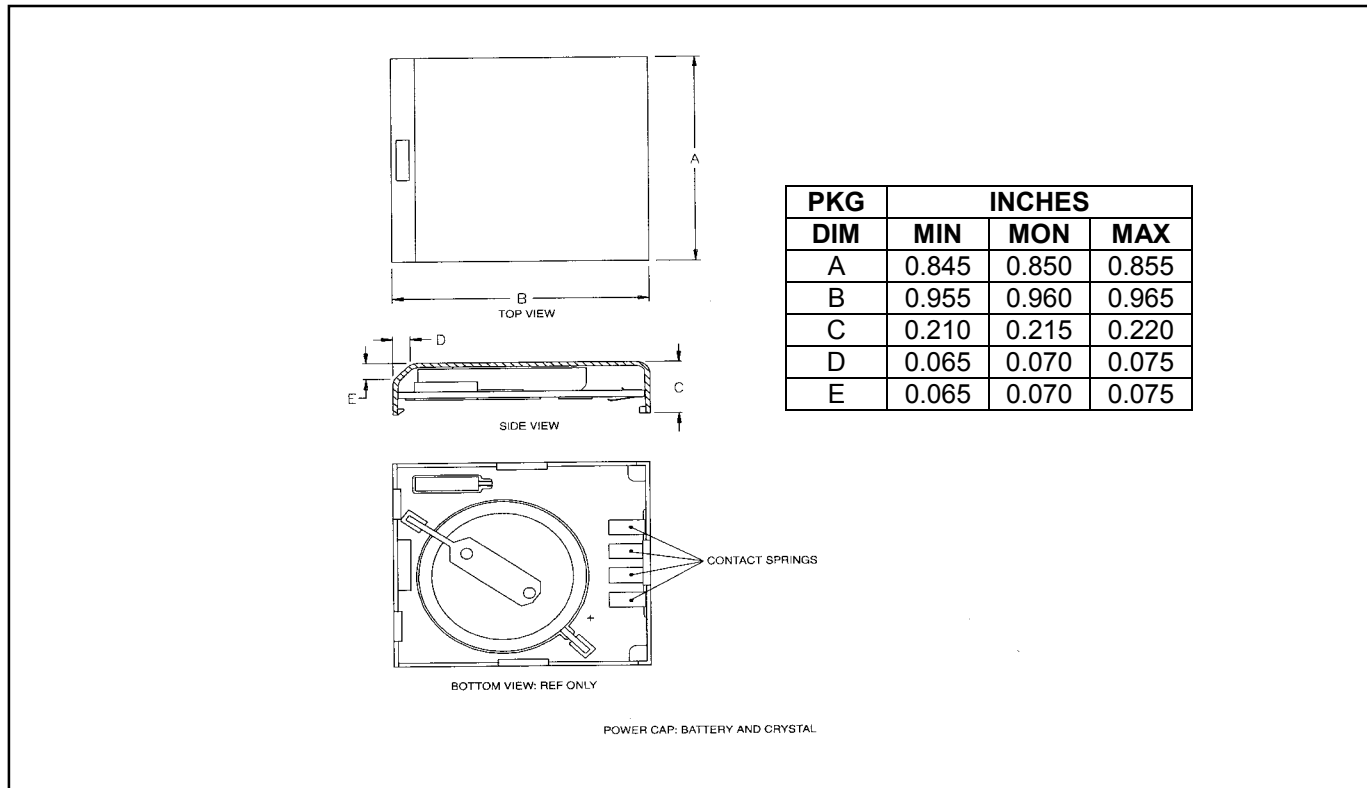

ATTENTION: BATTERY COMPONENT

The DS9034PCX contains a lithium battery. Do not short, ground, or apply external voltages to the electrical portions of this device. Do not expose to temperatures over 85°C. Do not subject this device to any type of cleaning process. Store only in nonconductive containers. Failure to observe these precautions may result in battery discharge or decreased battery life.